



**Technical Service Manual
for 13SEER DC INVERTER 24K**

Model	Remarks
KFHHP-22	1PH 208/230V R410A

2 Specifications and technical parameters

Model	KFHHP-22	
Function	COOLING	HEATING
Rated Voltage	208-230V~	
Total Capacity (W)	23800/22000Btu	27000/24200Btu
Rated Input (W)	2240	2280
Rated Current (A)	10.18	10.36
Air Flow Volume (m ³ /h) (H/ML)**	1050/950/880	
Dehumidifying Volume (l/h)	3	
Indoor Unit	Model of Indoor Unit	KFHHP-22-ID
	Fan Motor Speed (r/min)	1400/1300/1200
	Output of Fan Motor (w)	20
	Input of Heater (w)	/
	Fan Motor Capacitor (uF)	3
	Fan Motor RLA(A)	0.4
	Fan Type-Piece	Cross flow fan – 1
	Diameter-Length (in)	φ4.17 X35.04
	Evaporator	Aluminum fin-copper tube
	Pipe Diameter (in)	Φ0.28
	Row-Fin Gap(in)	2-0.055
	Coil lengthxheightxcoil width(in)	35.5X0.083X15
	Swing Motor Model	MP24GA
	Output of Swing Motor (W)	2
	Fuse (A)	PCB 3.15A Transformer 0.2A
	Sound Pressure Level dB (A)	52/50/48
	Sound Power Level dB (A)	62/60/58
Dimension (in)	46.38 X12.83X8.94	
Dimension of Package(in)	49.8X16.42X13.11	
Net Weight /Gross Weight(lb)	38.6/53	

Outdoor unit	Model of Outdoor Unit		KFHHP-22-OD
	Compressor Model		C-6RZ146H1A
	Compressor Type		Rotary
	L.R.A. (A)		40
	Compressor RLA(A)		8.4
	Compressor Power Input(W)		1640
	Overload Protector		1NT11L-3979
	Throttling Method		Capillary throttling
	Starting Method		Transducer starting
	Working Temp Range (°C)		(-10~43°C)
	Condenser		Aluminum fin-copper tube
	Pipe Diameter (in)		φ0.3748
	Rows-Fin Gap(in)		2-0.055
	Coil lengthxheightxcoil width(in)		26.9X32X1.73
	Fan Motor Speed (rpm)		780/600
	Output of Fan Motor (W)		60
	Fan Motor RLA(A)		0.25
	Fan Motor Capacitor (uF)		3
	Air Flow Volume of Outdoor Unit		/
	Fan Type-Piece		Axial fan -1
	Fan Diameter (in)		φ18.11
	Defrosting Method		Auto defrost
	Climate Type		T1
	Isolation		I
	Moisture Protection		IP24
	Permissible Excessive Operating Pressure for the Discharge Side(MPa)		4
	Permissible Excessive Operating Pressure for the Suction Side(MPa)		/
Sound Pressure Level dB (A)		59/58	
Dimension (W/D/H)(in)		37.4X16.22X33.07	
Package Dimension(W/D/H)(in)		43.3X17.7X35.6	
Net Weight /Gross Weight (lb)		141.1/152.1	
Refrigerant Charge (oz)		R410a/84	
Connection Pipe	Length (ft)		26.25
	Outer Diameter	Liquid Pipe (mm)	Φ9.52(3/8")
		Gas Pipe (mm)	Φ16(5/8")
	Max	Height (ft)	40
	Distance	Length (ft)	100

The data above is subject to change without notice .Please refer to the nameplate of the unit



Components name

Indoor unit

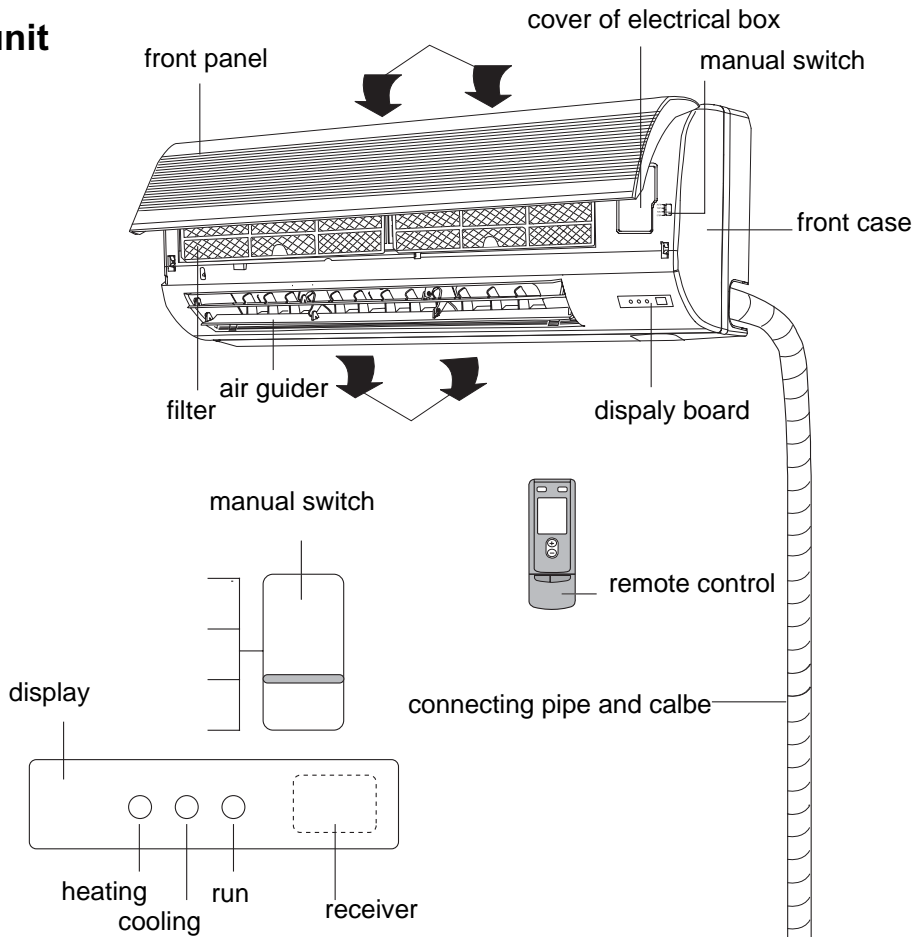

Outdoor unit

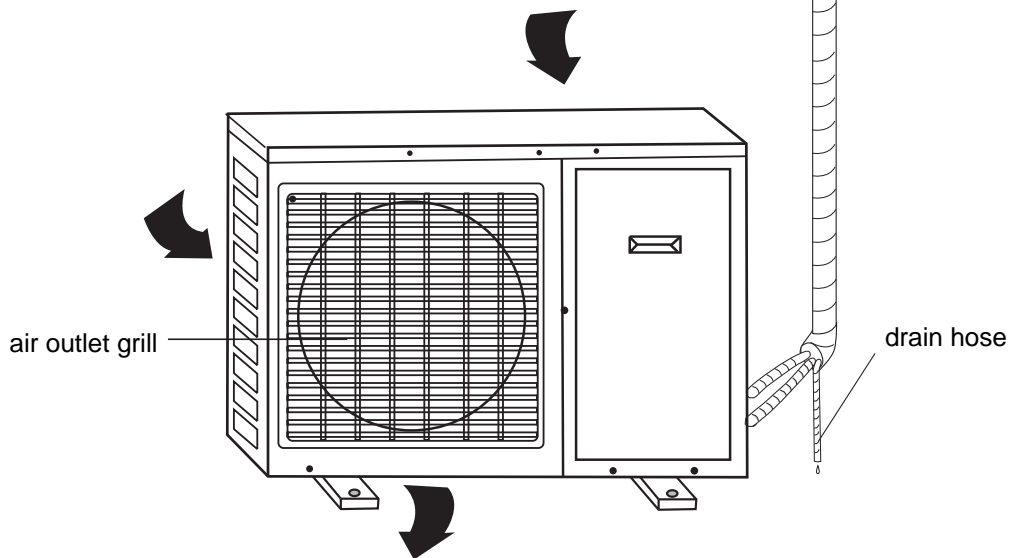

4 Overall and installation dimension

4.1 Overall and installation dimension of indoor unit KFHHP-22-ID

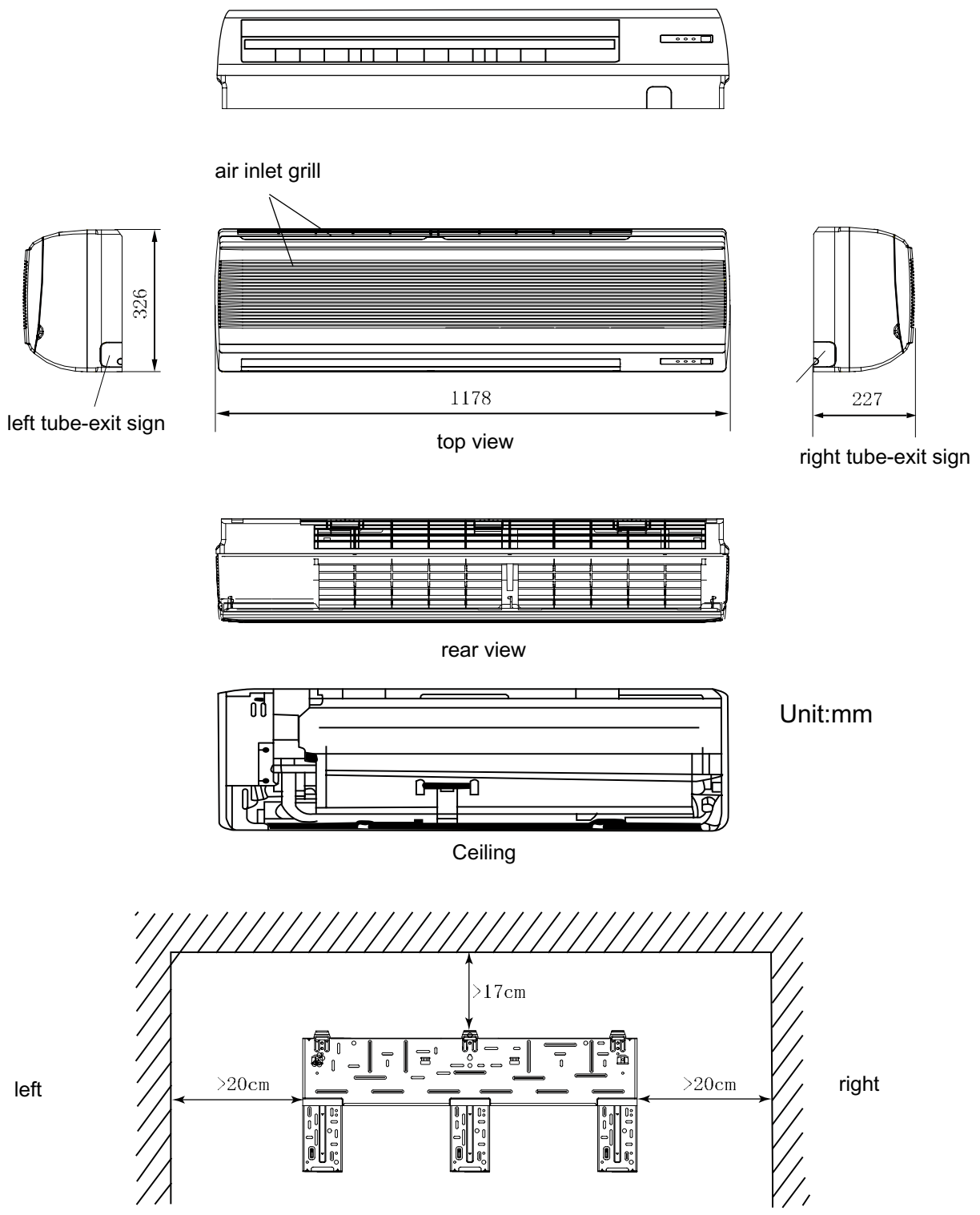

Overall and installation dimension of outdoor unit KFHHP-22-OD

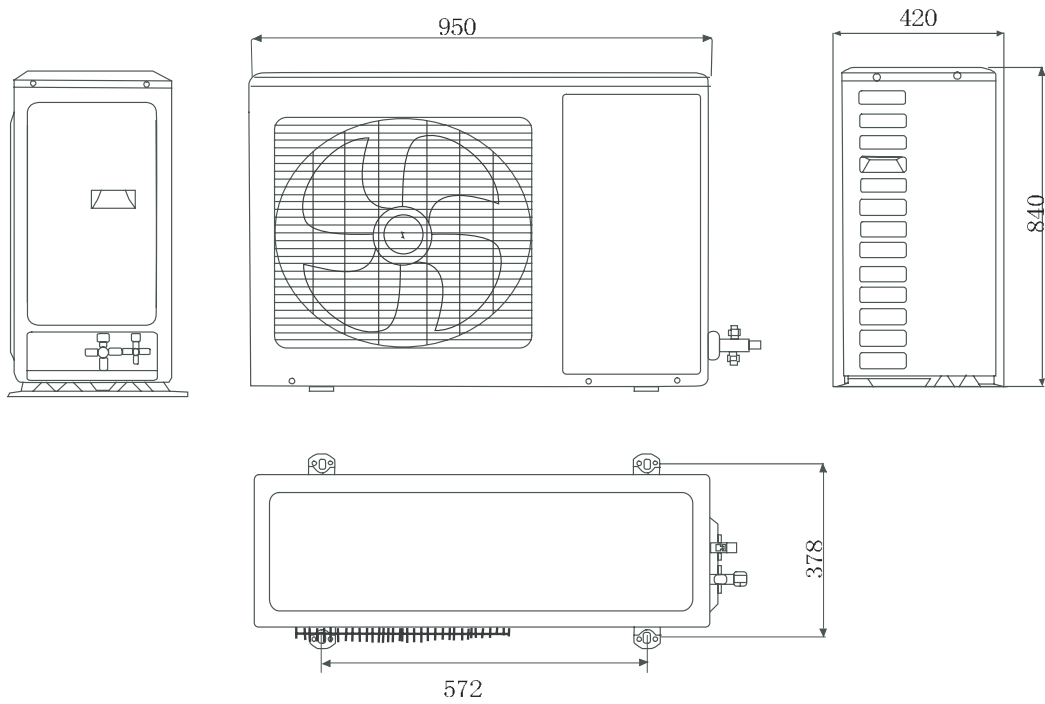

unit :mm

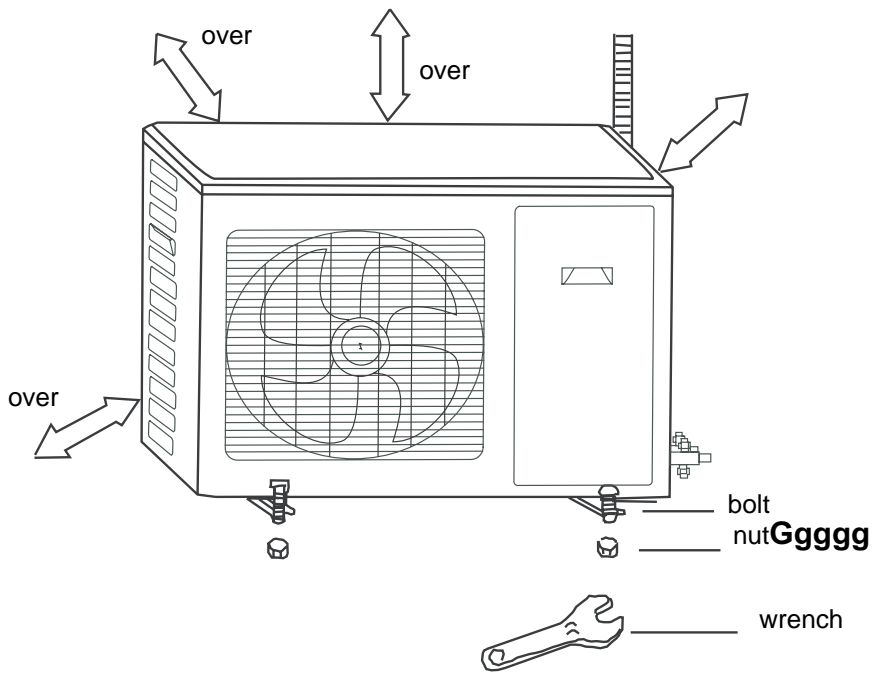

5 Electrical diagram

KFHHP-22

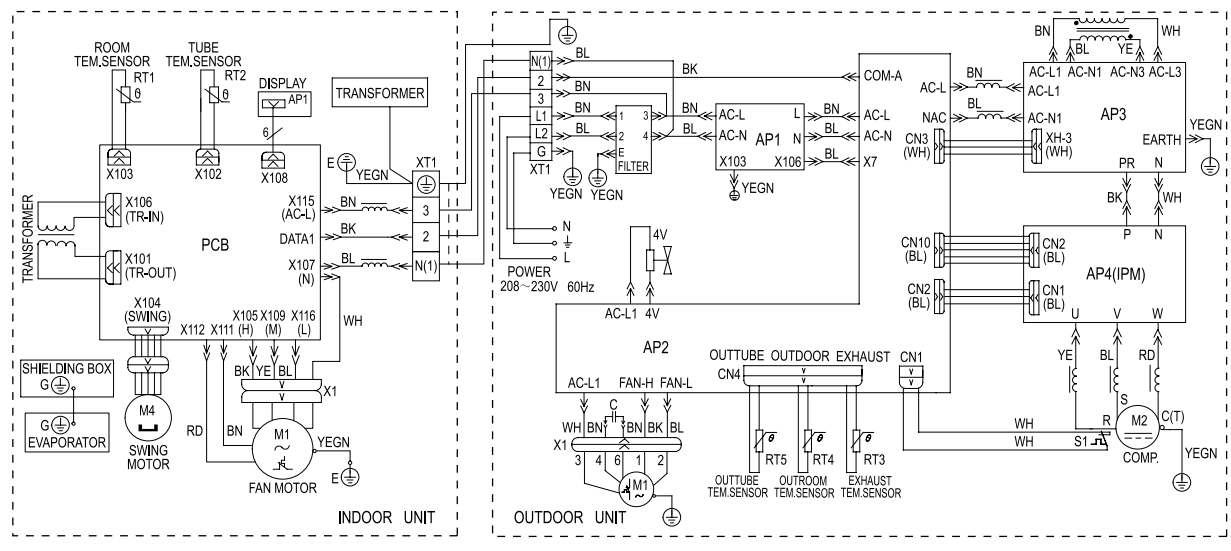

The diagram above is subject to change without notice. Please refer to the diagram label on the unit

6

Function manual and operating method of controller

6.1 Function manual

6.1.1 Temperature parameters

- ◆ Room set temperatures(Tset)
- ◆ Room ambient temperatures(Tin-amb)

6.1.2 Fundamental function

6.1.2.1 Cooling mode

- temperature setting range is 16-30°C
- under this mode, fan motor of indoor unit operates at setting speed.
- when compressor stops because of malfunction protection, fan motor of indoor unit still operates at setting speed.

6.1.2.2 Dehumidifying mode

- Temperature setting range is 16-30°C
- Indoor fan motor runs at low setting speed.
- when compressor stops because of malfunction protection, indoor motor still operates at low speed.

6.1.2.3 Fan mode

- Temperature setting range is 16-30°C
- Indoor fan can operate at selected speed of HIGH,MED,LOW and AUTO.

6.1.2.4 Heating mode

- Temperature setting range is 16-30°C
- sending out remaining heat: after indoor fan runs at setting speed for 60s
- anti cold air: indoor fan will start in 2 minutes at latest
- when compressor stops at setting temp., indoor fan motor operates in discharging remaining heat
- when compressor stops because of malfunction protection, indoor fan runs in discharging remaining heat.
- on receiving signal of defrosting, indoor fan motor stops; when defrosting ends, fan motor runs under anti cold air status.

6.1.2.5 Auto mode

In this mode, indoor fan will run in Cooling, heating, air discharging mode according to the change of ambient temperature. And the protection function is the same as under Cooling, Heating mode.

6.1.3 Other control

6.1.3.1 auto control of speed of indoor fan

indoor fan runs automatically at HIGH,MED,LOW speed according to the change of ambient temperature. The interval of speed switching is 3 minutes and 30 seconds at least. When in dehumidifying mode, fan runs at setting low speed.

6.1.3.2

when the power is on, the air guide louver will turns to A position counter-clockwise and closes the air outlet vent.; after the unit starts in heating mode, it turns to the max air outlet position D2; after unit starts in cooling mode, it will turns to D1 position and then back to L1 position; when in swinging state, it will swing between L1 and D1 in cooling; between L and D2 in heating. After the unit is off, it will turns back to A position to close the air outlet vent.

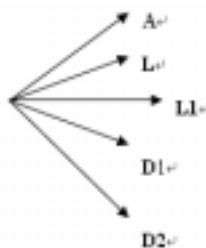

6.1.3.3 Timer control

The auto-start timer function can be set when the unit is off. When it reaches the time, the controller will function in the originally set mode. The interval is 0.5 hour and the range of timer is 0.5-24 hours.

The auto-stop timer can be set when the unit is on. When it reaches the time, unit will be off automatically. The interval is 0.5 hours and range of timer is 0.5-24 hours.

6.1.3.4 Sleep control

When units in cool or dry mode, after sleep mode has been set properly, the preset Tset will be increased by 1°C after sleep program has run for 1 hour. And Tset will be increased by another 1°C after 2 hours. Tset has been increased by 2°C totally in two hours. Then the unit will run at this set temperature and at the set speed.



When unit is in HEAT mode, after sleep mode has been set properly, the preset Tset will be increased by 1°C after the sleep program has run for 1 hour, and Tset will be decreased by another 1°C after 2 hours. Tset has been increased by 2°C totally in two hours. Then the unit will run at this temperature and at the set speed.

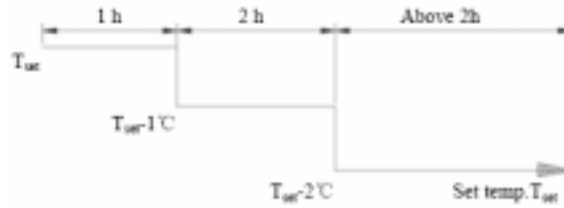

In Auto OR fan mode, the setting temp. will not change.

6.1.3.5 Toggle switch

1, If memory function is on, when unit is power-on and start operation and toggle switch is in STOP position, the unit will operate with STOP position; or else unit starts under power-off memory. There is memory function with AUTO, RUN, STOP position. TEST position is without memory function.

2, If there is no memory function, unit will operate under previous switch position.

★ When toggle switch is on AUTO, unit operates in AUTO mode, and air swing on; if there is signal of remote control, then unit operates according to signal.

★ When toggle switch is on TEST, indoor fan runs in high speed, and air swing on; indoor unit sends out signal of Cool mode on 16°C and 30°C ambient temperature to outdoor unit. If malfunction of indoor or outdoor temp. sensor is detected, buzzer will give out beep to alarm. If there is signal of remote control, unit operates as per remote control and indoor unit sends remote control signal to outdoor unit.

6.1.3.6 Communication failure

Communication failures happen if there is no correct signal received for 3 minutes

6.1.3.7 Buzzer control

When unit is power on or receiving remote control signal or the toggle switch is pressed, the buzzer will give out a beep.

6.1.3.8 Power-off memory function

- 1) contents of memory: mode(AUTO, COOL, DEHUMIDIFYING, HEATING, etc), setting fan speed, setting temperature, Timing etc.
- 2) if unit was on when power off, 3 minutes is delayed for indoor unit to send signal of starting to outdoor unit.
- 3) When power is on again, unit will operate in previous mode before power-off.
- 4) If there was no timer function in the last remote control dictation, then unit will memorize the last remote control dictation and operate according to the previous mode
- 5) If there was timer function in the last remote control dictation and system was power-off before the time set, unit will memorize the last timer function and it will time from the begin of restarting.
- 6) If there was timer function in the last remote control dictation and system was power-off at the time set, unit will operate in the mode before power-off but timer won't be on.

6.1.3.9 Failure detect of indoor temp. sensor

When unit is defrosting, temp sensor malfunction is not under detection. In other status temp sensor malfunction of indoor ambient and tube are under malfunction. If the temperature is not between the minimum and maximum for continuous 30s, signal of error will be sent out.

When indoor temp sensor failures, it will send signal of closing down unit to outdoor unit.

6.1.3.10 Method for testing (min, med, nominal, max cooling or heating)

Temp. set in remote control	16	17	18	19
In Cool mode, press Sleep button 4 times in succession within 3 seconds	Min. cooling	Med. Cooling	Nominal cooling	Max. cooling
Temp. set in remote control	27	28	29	30
In Heat mode, press Sleep button 4 times in succession within 3 seconds	Min. heating	Med. heating	Nominal heating	Max. heating

Press any button to exit.

Cooling mode: temperature signal sent to outdoor unit is compulsively set 16°C when cooling capacity is min, med, nominal or max.

Heating mode: temperature signal sent to outdoor unit is compulsively set 30°C when heating capacity is min, med, nominal or max.

Notice: when test is started, relevant indicating lamp blinks quickly. If there is malfunction, it will be displayed directly

Controller function of outdoor unit

6.1.1 Parameters of temperature

Exhausting gas temperature of outdoor unit(Tex)

Ambient temperature of outdoor unit(Tam)

6.1.2 Fundamental function of system

In whichever mode, once compressor start-up, it can only be close down 6 minutes later at least(not including malfunction protection/mode switch which requires compressor to stop);Once compressor closes down, it can only restart 3 minutes later at least(including mode switch, stop by remote control etc.);compressor starts up after outdoor motor runs for 5 seconds

6.1.2.1 Cool mode

6.1.2.1.1 Working conditions and process of cooling

●when compressor in closing down state and $(T_{in-amb}-T_{set}) \geq 0.5^{\circ}\text{C}$,if unit start in cooling mode, then cooling mode operates; outdoor fan motor and compressor start to run. The frequency of compressor can be adjusted automatically according to need of cooling power by micro-computer.

●during cooling process, when $0^{\circ}\text{C} \leq (T_{set}-T_{in-amb}) \leq 2^{\circ}\text{C}$,the compressor operates in low frequency.

●during cooling process, when 0 need of cooling power and $(T_{set}-T_{in-amb}) > 2^{\circ}\text{C}$, then compressor stops running. And outdoor fan motor stops in 60s.

》 In this mode, there is no power supply for reversing valve. Range of temperature setting is 16-30 $^{\circ}\text{C}$.

6.1.2.1.2 Frost-proof protection

In cool and dehumidifying mode, when frost-proof protection is detected, the compressor will run in lower frequency or stops. And outdoor fan motor stops in 60s. When frost-proof protection ends, Compressor resumes running.

6.1.2.1.3 Controlling principles of outdoor fan motor

If $T_{out-amb} \geq 26^{\circ}\text{C}$, the fan motor runs in high speed.

If $T_{out-amb} \leq 24^{\circ}\text{C}$, the fan motor runs in low speed.

If $24^{\circ}\text{C} < T_{out-amb} < 26^{\circ}\text{C}$, the fan motor runs in original speed.

After fan motor runs in compulsive high speed for 3 minutes in starting-up, then the speed will be controlled by the set principles

6.1.2.2 Dehumidifying mode

●Working conditions and process of dehumidifying: the same with the ones in cooling mode

●status of 4-way valve: closed

●range of temperature setting: 16-30 $^{\circ}\text{C}$

●protection function: the same with the ones in cooling mode.

6.1.2.3 Fan mode

●compressor, outdoor fan motor and 4-way valve are closed and stopped.

●range of temperature setting: 16-30 $^{\circ}\text{C}$

6.1.2.4 Heating mode

6.1.2.4.1 Working conditions and process of heating

●when compressor in closing down state and $(T_{in-amb}-3)^{\circ}\text{C} \leq (T_{set}-0.5)^{\circ}\text{C}$, if unit start in heating mode, then heating mode operates. Outdoor fan motor ,compressor and 4-way valve start to run.

The frequency of compressor can be adjusted automatically according to need of heating power by micro-computer.

- during heating process, when $T_{set} \text{ } ^\circ\text{C} \leq (T_{in-amb}-3) \text{ } ^\circ\text{C} \leq (T_{set} +2)^\circ\text{C}$, the compressor operates in low frequency.

during heating process, when $(T_{in-amb}-3) \text{ } ^\circ\text{C} > (T_{set} +2)^\circ\text{C}$, then compressor stops running. And outdoor fan motor stops in 60s.

Notice: It will take 2 minutes to power-off in 4-way valve when the unit closes down in heating mode or switch from heating mode to other modes.

» In this mode, there is power supply for reversing valve. Range of temperature setting is 16-30°C.

6.1.2.4.2 Controlling principles of outdoor fan motor

If $T_{out-amb} \leq 19^\circ\text{C}$, the fan motor runs in high speed.

If $T_{out-amb} \geq 21^\circ\text{C}$, the fan motor runs in low speed.

If $19^\circ\text{C} < T_{out-amb} < 21^\circ\text{C}$, the fan motor runs in original speed.

After fan motor runs in compulsive high speed for 3 minutes in starting-up, then the speed will be controlled by the set principles

6.1.2.4.3 Defrosting process

When defrosting conditions is detected, if compressor run in high frequency, then frequency will be demultiplied first. Later compressor stops running and indoor fan motor stops. Outdoor fan motor stops in 50s later. 4-way valve will be power-off in 45s. The defrosting functions operates when compressor restart in 55s and frequency reaches 90hz. When the defrosting is over, the frequency will drop until it reaches 60hz. 50s later 4-way valve and outdoor fan motor will be power-on. Then frequency of compressor will rise to the required. But indoor fan motor have to start 2 minutes later at least.

If compressor closes down for malfunction in heating mode, indoor motor will only exhausting remaining heat.

6.1.3 Universal protection function of cool, heating, dehumidifying and auto mode

6.1.3.1 Overloading protection function

When over-high temperature of tube (T_{tube}) is detected, frequency of compressor will be demultiplied or limited. When T_{tube} is beyond maximum, compressor stops until T_{tube} restrores to normal value.

If there are 6 continuous times of over-high T_{tube} protection, compressor will stop and can not restart by itself. It can only be restart by pressing "ON/OFF" button. In operation if operating time of compressor is over 7 minutes, the number of times will be zero cleared.

6.1.3.2 Time-delay protection of compressor

Compressor will restart in 3 minutes after it closes down.

6.1.3.3 High exhausting gas temp. protection of compressor

When over-high temperature of gas exhausted (T_{ex}) is detected, frequency of compressor will be demultiplied or limited. When T_{ex} is beyond maximum, compressor stops until T_{tube} restrores to normal value.

If there are 6 continuous times of over-high T_{ex} protection, compressor will stop and can not restart by itself. It can only be restart by pressing "ON/OFF" button. In operation if operating time of compressor is over 7 minutes, the number of times will be zero cleared.

6.1.3.4 Current protection function

(1) overcurrent protection

If current of whole unit is beyond max. limit, unit will close down as if indoor temperature reaches the set temperature. Unit will restore automatically after compressor has been stop for 3 minutes.

If there are 6 continuous times of protection, compressor will stop and can not restart by itself and send signal of error to indoor unit. It can only be restart by pressing "ON/OFF" button. In operation if operating time of compressor is over 7 minutes, the number of times will be zero cleared.

(2) frequency demultiplied, limitation of current control

If current of whole unit is high, frequency of compressor will be demultiplied or limited. If normal current value is detected, whole unit restore to operate normally.

6.1.3.5 Communication failure

When there is no right signal from indoor unit for continuous 3 minutes or no right signal from driving slug within 60s, communication failure happens. Outdoor unit will closes down.

6.1.3.6 Module protection

Compressor will detect signal of module protection right away after it starts. Compressor closes down in module protection status as if room temperature reaches the set value. And relevant error is displayed. Compressor restores to run after stopping for 3 minutes.

If there are 6 continuous times of protection, compressor will stop and can not restart by itself. It can only be restart by pressing "ON/OFF" button. In operation if operating time of compressor is over 7 minutes, the number of times will be zero

6.1.3.7 overheating protection of module

When IPM temperature is too high, frequency of compressor will be demultiplied or limited. When IPM temperature is beyond maximum, compressor closes down. The whole unit can only restart when IPM temperature returns to norm and compressor has been stopping for 3 minutes.

If 3 times of IPM temperature protection happens in 1 hour, compressor will stop and can not restart by itself. It can only be restart by pressing "ON/OFF" button.

6.1.3.8 overloading protection of compressor

When overloading switch of compressor operates, it will closes down as if room temperature reaches set value. Whole unit can only restart when compressor has been stopping for 3 minutes and overload switch resets.

6.1.3.9 PFC protection

When air conditioner starts in cooling, heating or dehumidifying mode, compressor starts and frequency rises to 30hz. PFC protection is on after it runs for 30s.

Compressor closes down in whatever condition, PFC and compressor closes down at the same time.

PFC protection signal will be detected once after PFC starts; when PFC protection is on, PFC and compressor closes down at the same time.

PFC restores automatically 3 minutes later after failure happens

6.1.3.10 Testing of malfunction of temp. sensor and IPM overheating

(1) In stand-by status outdoor tube temperature sensor, ambient temperature sensor and sensing device error of overheating IPM are not under detection.

(2) error of temp. sensor of exhausting gas and error of IPM overheating will be under detection after the whole unit is on and compressor operates for continuous 3 minutes.

(3) within 10 minutes after compressor starts or within 10 minutes after defrosting or oil returning in heating mode, error of outdoor tube temp. sensor are not under detection.

(4) when error of IPM overheating or failure of temp. sensor is detected, whole unit will closes down immediately.

6.1.3.11 The status of indicator in outdoor unit

Notice: When the unit is power-on again, the times of all the protection above (including: overloading protection, high exhausting gas temp. protection of compressor, overcurrent protection, module protection etc.) will be reset.

D11	Meaning	D12	Meaning	D13	Meaning
blink 1 time	compressor starts to run	blink 1 time	cooling overload protection stop	blink 1 time	quick cooling/heating
blink 2 times	exhaust protection stop	blink 2 times	heating overload protection stop	blink 2 times	defrosting
blink 3 times	closing down for NEC driving module protection	blink 3 times	communication failure with indoor unit	blink 3 times	oil returning
blink 4 times	closing down for overcurrent protection	blink 4 times	communication failure with NEC module	blink 4 times	nominal cooling/heating
blink 5 times	closing down for overloading protection	blink 5 times	communication failure with computer	blink 5 times	max. cooling/heating
blink 6 times	cooling antifreezing stop	blink 6 times	failulre of outdoor ambient temp.sensor	blink 6 times	medial cooling/heating
blink 7 times	sensor malfunction stop	blink 7 times	failure of outdoor tube-temp.sensor	blink 7 times	min.cooling/heating
blink 8 times	closing down for communication failure(including indoor unit and NEC driving module)	blink 8 times	failure of outdoor gas-discharge temp.sensor	blink 8 times	unit off
blink 12 times	closing down for IPM overheating protection	blink 9 times	communication failure sent from indoor	blink 9 times	low pressure and can't resume
		blink 10 times	wrong parameters sent to NEC driver, unit closes down		
		blink 11 times	IPM temp. sensor failure		
D14	meaning	D15	meaning	D16	meaning
blink 1 time	frequency demultiplied for high temp.of gas discharged	blink 1 time	frequency limiting for high temp.of gas discharged	on	Be receiving or sending computer data
blink 2 times	frequency demultiplied for overcurrent protection	blink 2 times	frequency limiting of overcurrent protection	off	receiving or sending computer data finished
blink 3 times	frequency demultiplied for cooling overload	blink 3 times	frequency limiting for cooling overloading		
blink 4 times	frequency demultiplied for heating overload	blink 4 times	frequency limiting for heating overloading		
blink 5 times	frequency demultiplied for frost-proof	blink 5 times	frequency of current 9.4 A lasting for 2 minutes		

D14	Meaning	D15	Meaning	
blink 6 times	Unit closing down for min.frequency	blink 6 times	frequency of current 12 A lasting for 2 minutes	
blink 7 times	Unit closing down for PFC protection	blink 7 times	frequency limiting or demultiplied for rate of frequency variation out of control	
blink 8 times	Unit closing down for compressor overloading	blink 8 times	frequency limiting or demultiplied of compressor current	
		blink 9 times	frequency limiting or demultiplied for over temp.of IPM module	
D17	Meaning	D18		Meaning
blink 1 time	too low DC input voltage	when no short-circuit in computer monitor port	On	receiving or sending indoor data
blink 2 times	too high DC voltage	computer monitor port	off	receiving or sending indoor data finished
blink 3 times	AC current protection	short-circuit in computer monitor port	blink	normal communication between main board and driving board
blink 4 times	IPM abnormality		not blink	abnormal communication between main board and driving board
blink 5 times	reserved built-in PFC protection			
blink 6 times	start-up failure			
blink 7 times	phase-losing or out of control			
blink 8 times	first PFC protection ;then module protection			

7 Disassembly procedures

7.1 Disassembly procedures for indoor unit

Procedures and pictures

7.1.1 Disassembly front panel

(Refer to figure 7-1)

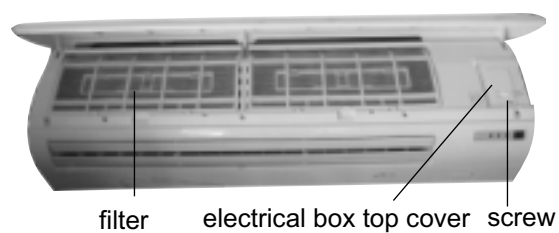

7-1

7.1.2 Disassemble filter

Push filter inside and pull it upward. Take the filter away
(Refer to 7-2)

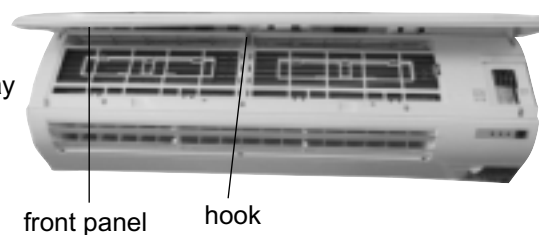

7-2

7.1.3 Disassemble guide louver

Bend the guide louver with strength and let out the hook
(Refer to figure 7-3)

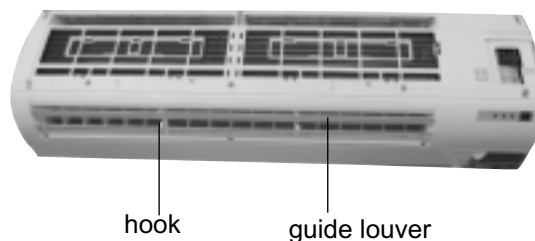

7-3

7.1.4 ||||| Disassemble front case

Unclench 3 screw covers; then unscrew 6 screws and lift it backward.
(Refer to figure 7-4)

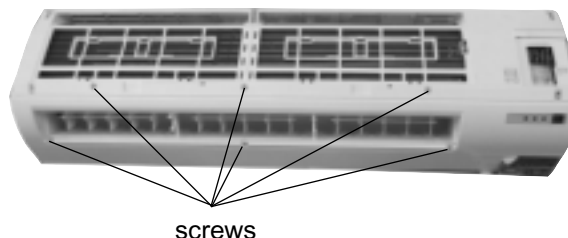

7-4

7.1.5 ||||| Disassemble electrical box cover

Unscrew the screw fixing the display board and take the board off. Hold the cover and press it to loosen the hook. lift it upward and remove the box cover
(Refer to figure 7-5)

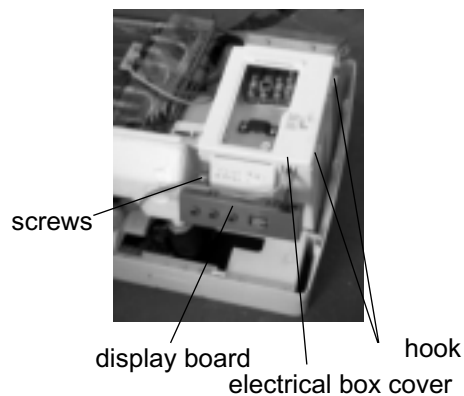

7-5

7.1.6 ||||| Disassemble electrical box

disassemble the grounding nut on evaporator; take away tube sensor
unplug the connecting terminal for indoor fan motor and stepping motor
Unscrew the screw fixing electrical box. Take out it.

(Refer to figure 7-6)

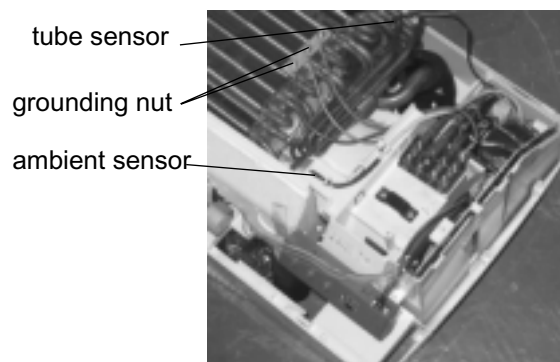

7-6

7.1.7 ||||| **Disassemble water tray**

Unloose the clasp fixing water tray; lift and disassemble it
(Refer to figure 7-7)

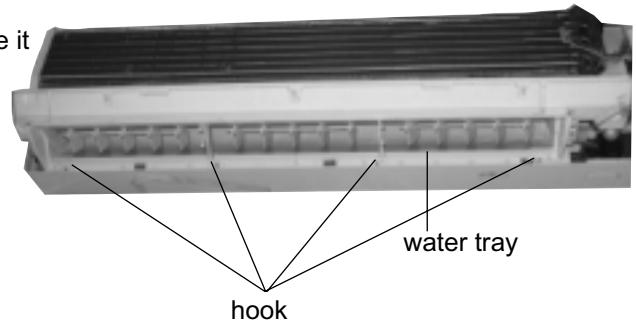

7.1.8 ||||| **Disassemble evaporator assy**

Unscrew 2 screws on the clamp and remove the clamp
unscrew the 2 screws fixing evaporator on left and right side.
Take out the evaporator by you hand and push it backward to let out
the side clasps from the groove. Take out the evaporator carefully
,protect the connecting pipe
(Refer to figure 7-8,7-9,7-10)

7-7

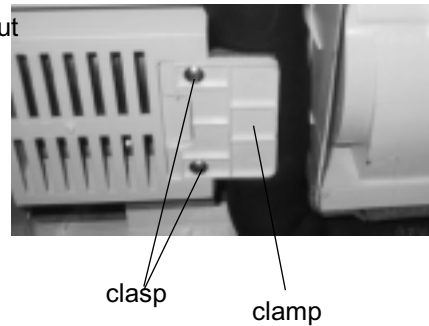

7-8

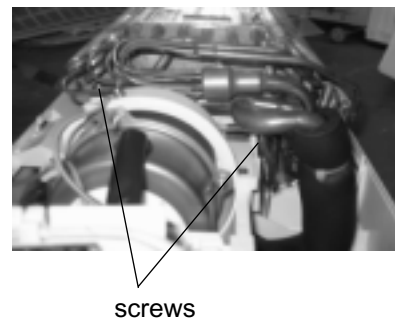

7-9



7-10

7.1.9 ||||| **Disassemble motor**

Unscrew the screws fixing press plate and take out press plate
Unscrew the one M4 screws and remove the motor

(Refer to 7-11)

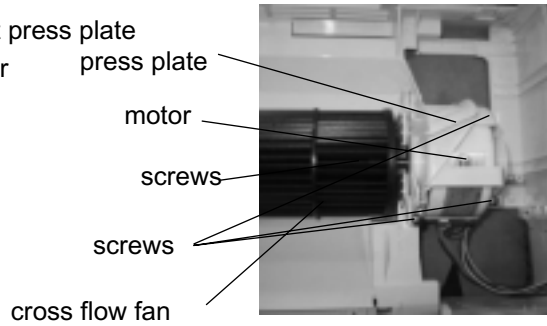

7-11

7.1.10 ||||| **Disassemble cross flow fan**

take out the bearing on the left and remove the cross flow fan

(Refer to 7-12)

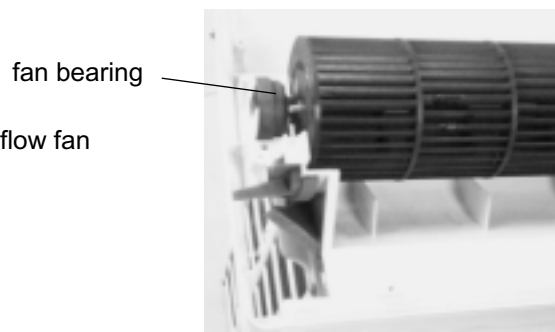

7-12

7.2 Disassembly procedures for outdoor unit

Operating procedures /pictures

7.2.1 Disassemble front side plate

unscrew the 4 screws around the front side plate and take off it
(Refer to figure 7-13)

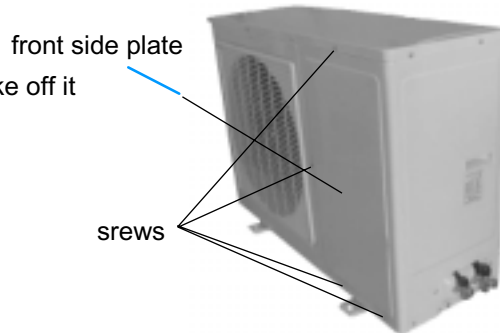

7-13

7.2.2 Disassemble top cover

Unscrew the screws around the top cover; lift the top cover and remove it
(Refer to figure 7-14)

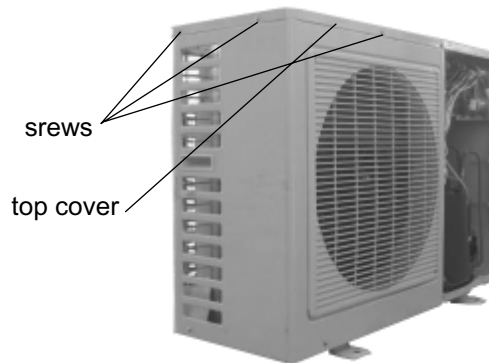

7-14

7.2.3 Disassemble rear grill

Unscrew the 4 self-tapping screws on rear side plate and take off the grill.

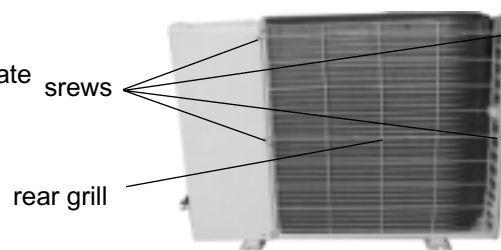

7-15

7. 2. 4 ||||| **Disassemble housing case**

unscrew the screws around the housing case and take off it

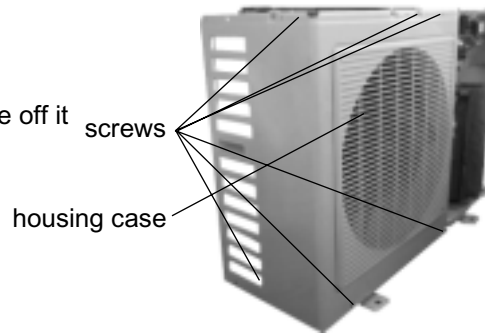

7-16

7. 2. 5 ||||| **Disassemble electrical box**

Screw out the 2 screws fixing the electrical box;
lift it and remove it.
(Refer to figure 7-17,7-18)



screws cover of electrical box

7-17

7. 2. 6 ||||| **Disassemble right side plate**

unscrew the 7 screws in right side plate, condenser side plate and
valve support; lift right side plate and remove it.
(Refer to 7-19)

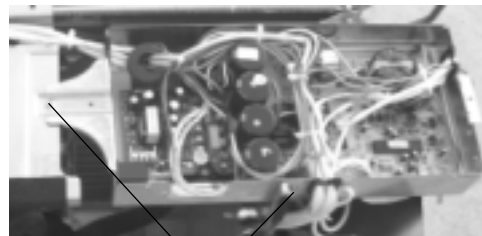

screws

7-18

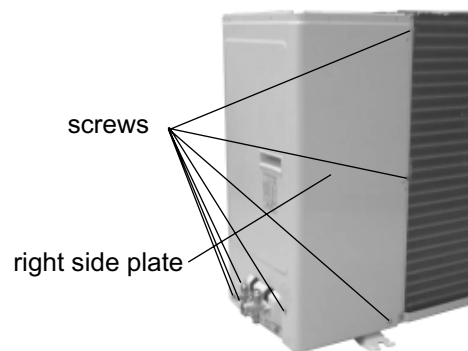

7 - 19

Operating procedures/pictures

7. 2. 10 ||||| Disassemble capillary

Unsolder the joint points between capillary and other pipelines;them it can be removed

(Refer to figure 7-23)

capillary

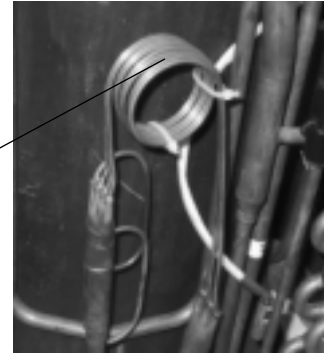

7-23

7. 2. 11 ||||| Disassemble valves

Unscrew the two screws fixing the big valve;unsoldering the soldering points between the big valve and air-return duct;remove big valve (When unsoldering,use wet cloth to wrap the big valve completely to prevent it from being harmed by high temperature.

Unscrew the 2 screws fixing small valve;unsolder the joint points between small valve and fork type pipe;remove small valve (Refer to figure 7-24)

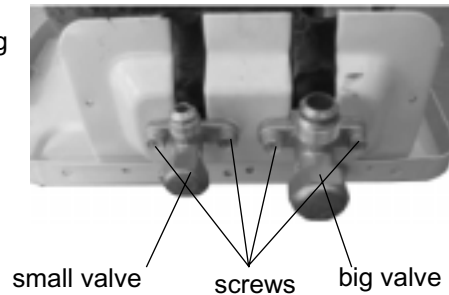

7-24

7. 2. 12 ||||| Disassemble compressor

Unsolder the soldering points between the pipes and compressor;unscrew the three nuts with washers at the foot of compressor;take out the compressor

(Refer to figure 7-25)

compressor

compressor nuts



Figure 7-25

8 Exploded view and components&part list

8.1 indoor unit KFHHP-22-ID

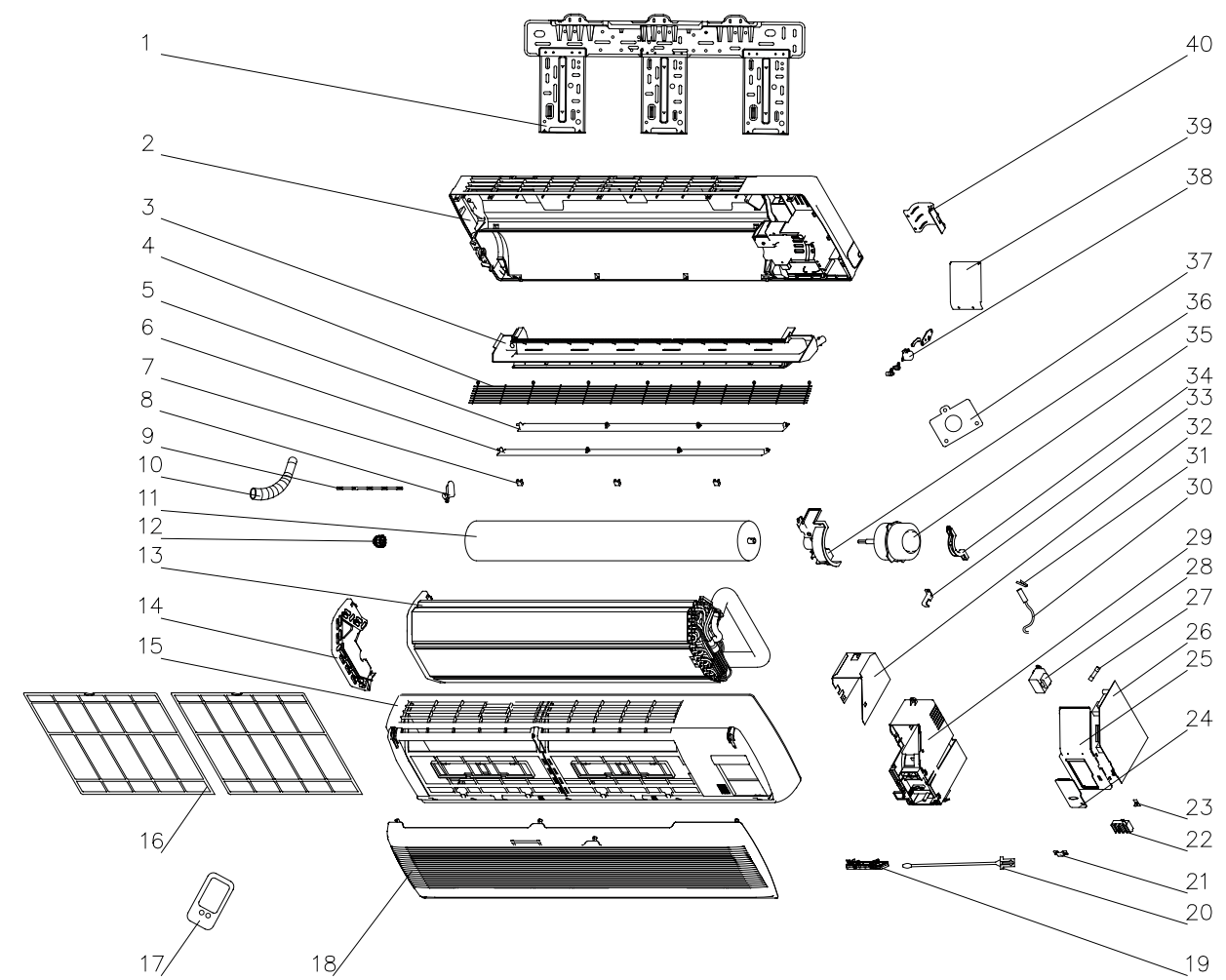

8. 2 Components and part list of indoor unit

No	Description	Part Code	Qty
		KFHHP-22-ID	
1	Wall-Mounting Frame	01252398	1
2	Rear Case	22202040	1
3	Water Tray	20182043	1
4	Rear Grill	01473007	1
5	Upper Air Deflector	10512062	1
6	Lower Guide Louver	10512063	1
7	Screw Cap	242520053	3
8	Air Louver	10512030	15
9	Swing Lever	10582040	3
10	Drain Pipe	05232411	1
11	Cross Flow Fan	10352420	1
12	O-Gasket of Cross Fan Bearing	76512203	1
13	Evaporator Assy	010041291	1
14	Evaporator Left Support	24212041	1
15	Front Case Sub-Assy	20002572	1
16	Filter Sub-Assy	11122051	2
17	Remote Control	30510029	1
18	Front Panel	20002375	1
19	Receiver Board	30046093	1
20	Ambient Temperature Sensor (15K)	390000451	1
21	Wire Clamp	71010103	1
22	Terminal Board	42011233	1
23	Toggle Switch	10582007	1
24	Electric Box Cover	201022521	1
25	Electric Box Cover	201022512	1
26	Main PCB M9WA25A	30039161	1
27	Fuse T3.15AL 250V	46010014	1
28	Transformer 41X26.5F	43110025	1
29	Electric Box	201022501	1
30	Tube Sensor (20K)	390000591	1
31	Sensor Insert	42020063	1
32	Lower Shield Cover for Electric Box	01592048	1
33	Fixed Clip	02112009	1
34	Motor Fixed Clip	26112069	1
35	Fan Motor FN30C	150121071	1
36	Retaining Plate of Evaporator	24212042	1
37	Sheet Metal Piece	02123005	1
38	Stepping Motor MP24GA	15212102	1
39	Upper Shield Cover for Electric Box	01592033	1
40	Pipe Clamp	26112071	1

8.3 Exploded view of outdoor unit

KFHHP-22-OD

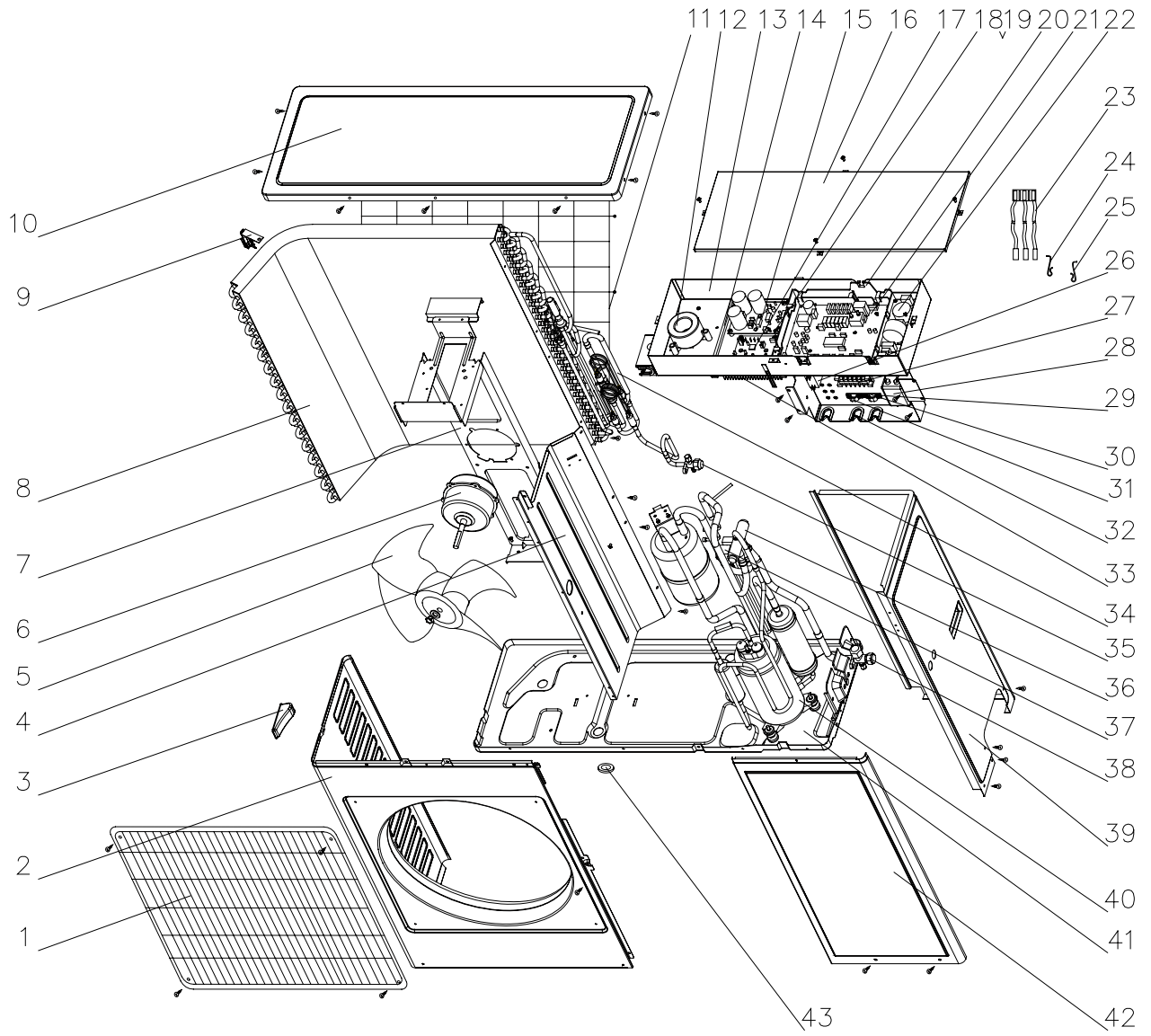

8. 4 Components and part list of outdoor unit

No	Description	Part Code	Qty
		KFHHP-22-OD	
1	Front Grill	01473001	1
2	Housing	01433011	1
3	Small Handle	26235401	1
4	Clapboard Assy	01233039	1
5	Axial Flow Fan	10335253	1
6	Fan Motor FW60H	15013704	1
7	Motor Support Sub-Assy	01703087	1
8	Condenser Assy	01103813	1
9	Temp Sensor Support	24213005	1
10	Top Cover	01255262	1
11	Rear Grill	01475252	1
12	Reactor	43120011	1
13	Electric Box Assy	01403591	1
14	Module Support	24213008	1
15	PCB JGP011	30111018	1
16	Electric Box Cover Sub-Assy	01403629	1
17	Main PCB 2 W9W2	30039165	1
18	PCB Support (up)	26153031	8
19	PCB Support (down)	24213010	8
20	PCB Support	24213009	1
21	Main PCB 1 W9W2	30039164	1
22	Filtering Board W9W2	30039163	1
23	Temperature Sensor	3900028001	1
24	Sensor Insert	42020063	1
25	Sensor Insert	42020066	1
26	Capacitor	33010027	1
27	Terminal Board	42010255	1
28	Filter	43130008	1
29	Wire Clamp	71010102	1
30	Isolation Washer	70410523	1
31	Wire Clamp	71010003	1
32	Cable-Cross Loop	76514004	5
33	Radiator	49013011	1
34	Capillary Sub-Assy	03103391	1
35	Cut-off Valve	07130209	1
36	4-way Valve	43000411	1
37	4-way Valve Fittings	4300040022	1
38	Gas Valve Sub-Assy	07103030	1
39	Rear Side Plate Sub-Assy	01302005	1
40	Compressor	00103501	1
41	Underpan Assy	01203560	1
42	Front Side Plate	01302007	1
43	Choke Plug	06813401	1

9 Troubleshooting

Analysis in this section is used for D.C. Variable Frequency Series. Before analysis, you can diagnose according to the code displayed on indoor unit or indicator display on outdoor unit. (Refer to Malfunction display section).

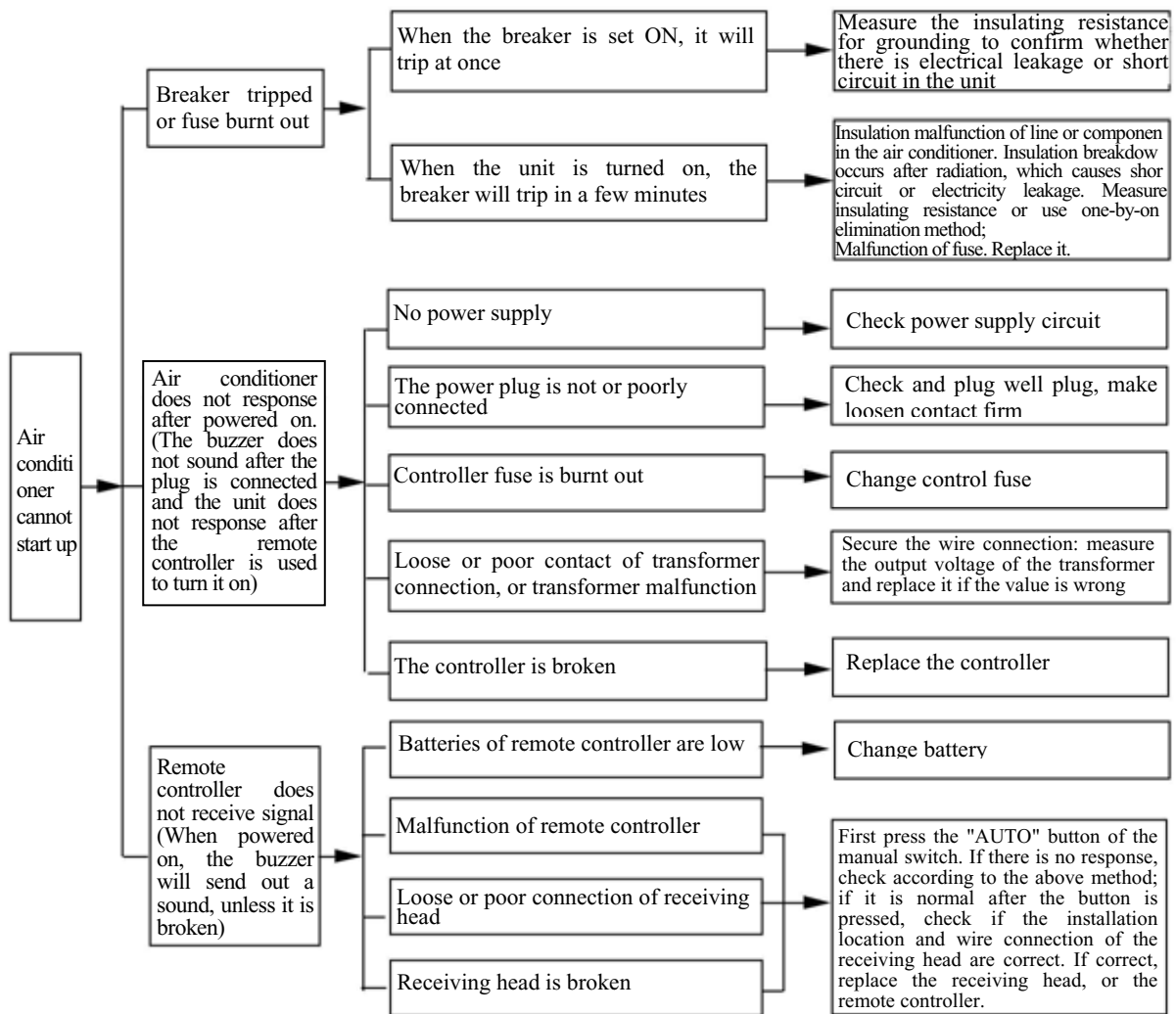

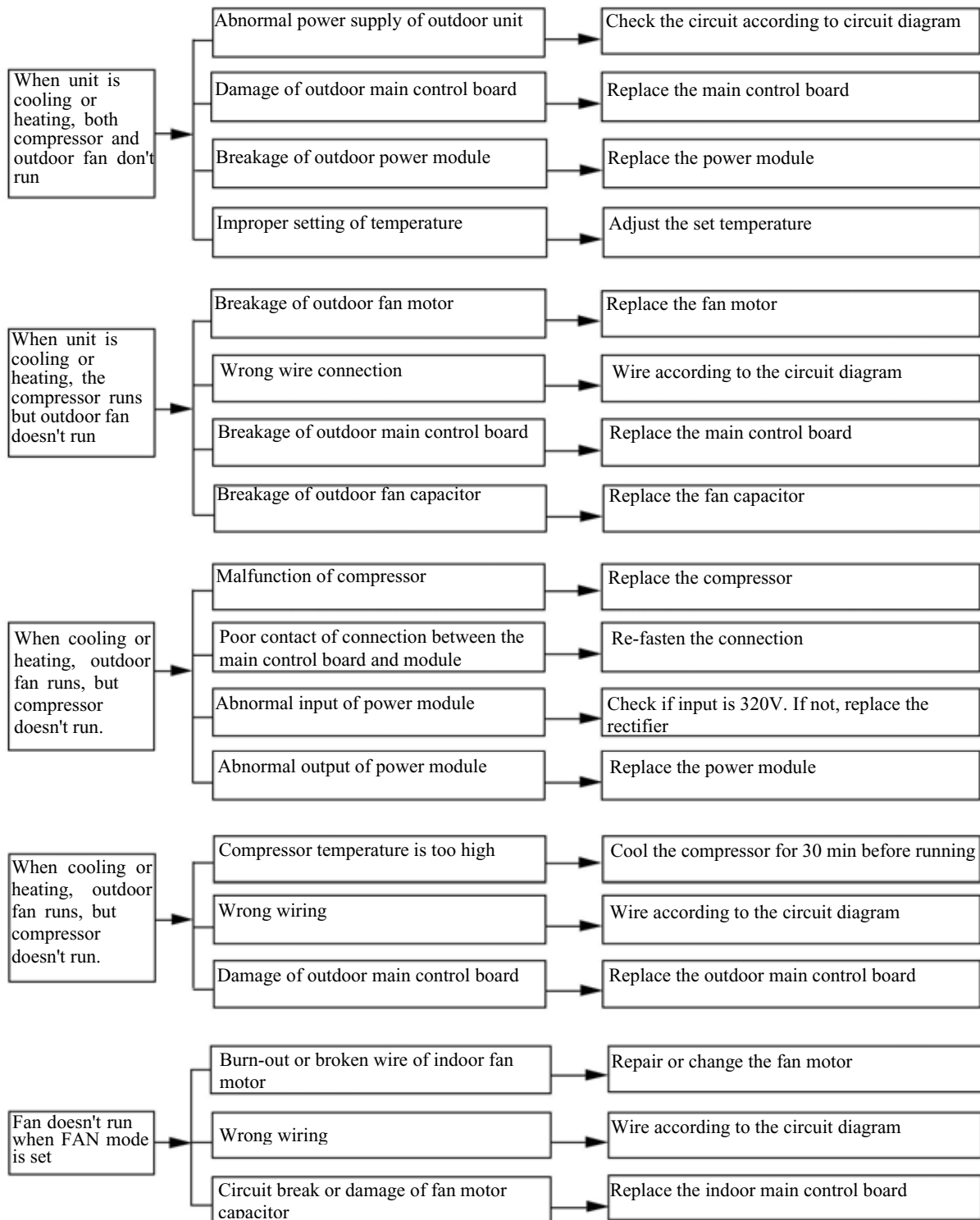

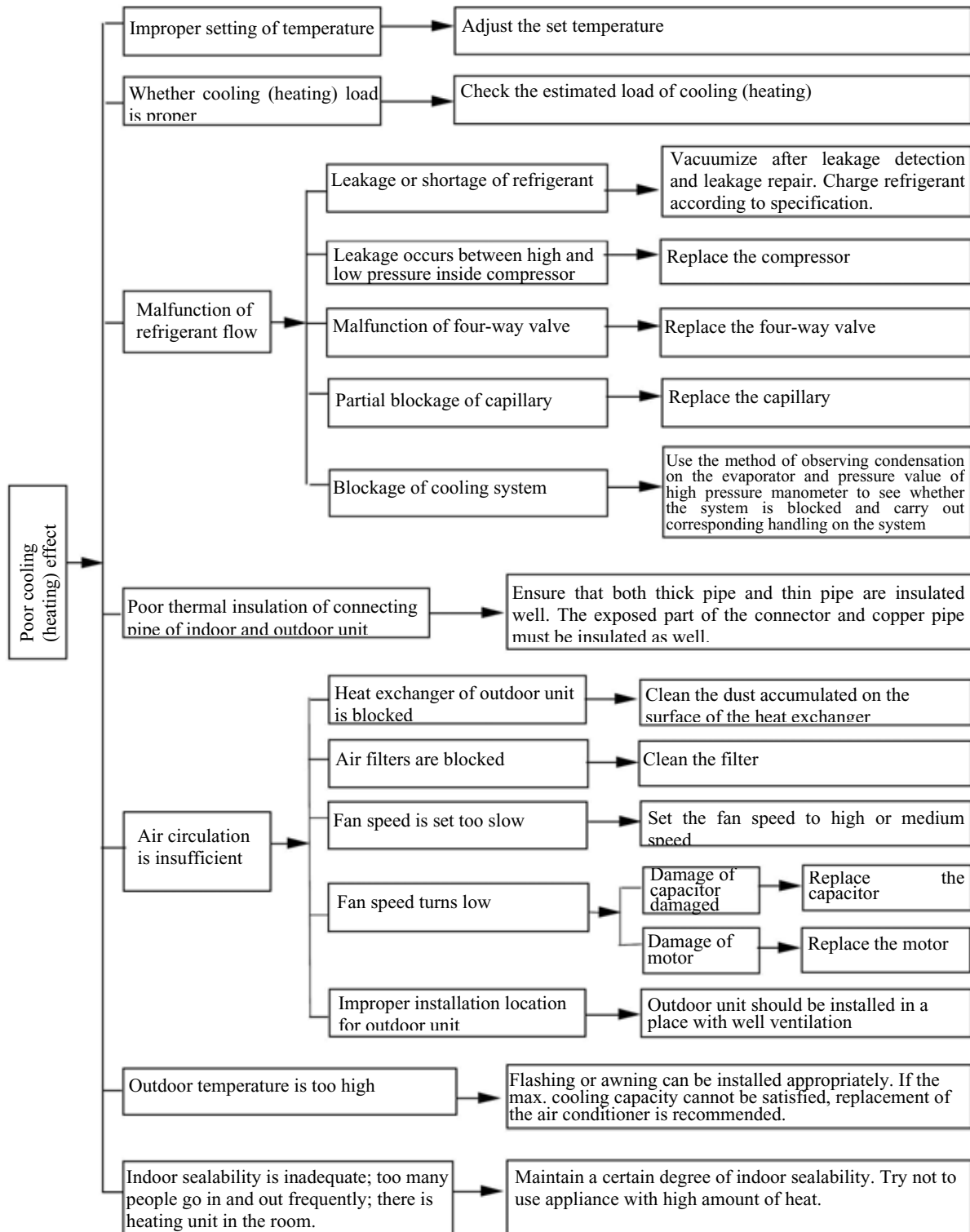

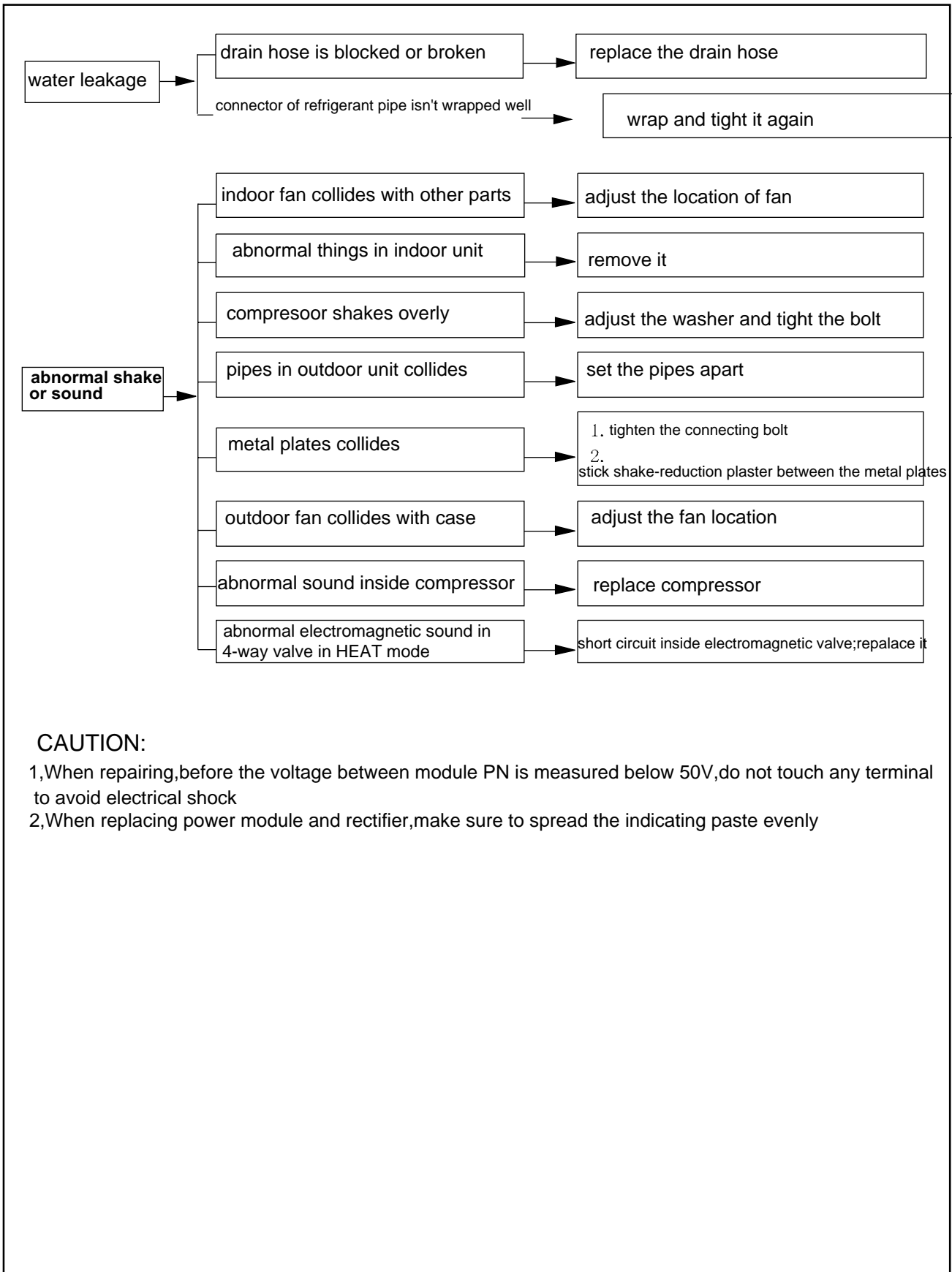

CAUTION:

- 1,When repairing,before the voltage between module PN is measured below 50V,do not touch any terminal to avoid electrical shock
- 2,When replacing power module and rectifier,make sure to spread the indicating paste evenly

9.2 Malfunction display section

Analysis or handling of some malfunction display:

1, Compressor discharge protection:

Possible reasons: shortage of refrigerant; block of air filter; poor ventilation or air flow short pass in condenser; system has noncondensing gas(ge. Water, air);blockage of capillary (including filter); leakage inside 4-way valve causes incorrect operations; malfunction of compressor; malfunction of protection delay; malfunction of gas discharge sensor; too high outdoor temperature.

Handling process: refer to the malfunction analysis in the above section

2, low voltage overcurrent protection:

Possible reasons: sudden drop of power supply or overloading

3, Communication malfunction:

Handling method: check if communication signal cable is connected reliably

4, temp sensor open or short circuit:

Handling method: check whether sensor is normal, connected with the corresponding position on the controller and if damage of lead wire is found

5, compressor overload protection:

Possible reasons: insufficient or too much refrigerant; blockage of capillary and increase of suction temp.; improper running of compressor, burning in or stuck of bearing, damage of discharge valve; malfunction of protector.

Handling method: adjust refrigerant amount; replace the capillary; replace the compressor; use universal meter to check if the contactor of compressor is fine when it is not overheat, if not replace the contactor.

6, system malfunction:

i.e overload protection. When tube temperaturec (Checking the temperature of outdoor heat exchanger when cooling and checking temperature of indoor heat exchanger when heating) is too high, protection will be activated.

Possible reasons: outdoor temperature is too high when cooling; insufficient outdoor air circulation; refrigerant flow malfunction.

7, IPM module protection:

Handing method: if module malfunctions and can not be restored for long time, please disconnect power supply. And connect again after about 10 minutes later. If repeating this method for several times and malfunction still exist, please replace the module.

8, PFC protection:

Possible reasons: outdoor temperature is too high; over-high temperature of PFC module; power of whole unit is too high and current is too high; low voltage in PFC; bad contact between the cables in PFC control board.

Handing method: If PFC protection happens, please check connecting cables of PFC board first. If the whole unit can not operate normally and PFC protection happens all the time, please replace PFC.

9, refrigerant charging:

Similar with the procedures of the over 5kw wall split models.

Notice: refrigerant charging can only be started after whole unit has been operating stably for about 10 minutes.

7. Module protection :

Handling method:

